



**Full Address: Horwich Leisure Centre, Victoria Rd,
Horwich, Bolton, BL6 5PY.**

We would like to wish all of you who have entered this event good luck with your final preparations for the race, we request that you read fully all the details outlined in this race information.

Please note however that it is sometimes necessary for last minute changes to be made and it is vital that you attend the race briefing on the day.

RULES GOVERNING THE EVENT

The event is affiliated to BTF and will be held under the rules of the British Triathlon Federation and competitors are advised to familiarise themselves with the rules and regulations that will be applied to this race, otherwise you may be penalised for breaking any rule. Ignorance is no defence! If you require further information about Race Rules, please visit www.britishtriathlon.org

TERMS AND CONDITIONS OF ENTRY

Terms and conditions of entry are clearly stated on the website www.epicevents.co.uk. In making the application competitors have agreed to abide by these terms and conditions of Epic Events and abide by the regulations of the governing body.

SWAPPING OF ENTRIES

Please note that the swapping of entries between competitors is strictly forbidden as it invalidates insurances undertaken by the organisers to cover

the event. If you are unable to race, please follow the instructions outlined in the terms and conditions on the www.epicevents.co.uk website.

COMPETITOR CONDUCT

Competitors are reminded that they share both the leisure facilities and the highway with other citizens who may or may not be fully aware of the event. We request that you treat both members of the public including other road users, marshals, other competitors, event officials and venue staff with respect. Any use of profanity or aggression towards any other parties will result in an immediate DQ from the event and a ban from all future events hosted by the promoters. Please try to remain courteous on the road even if some other road users may not offer you the same respect.

RULES GOVERNING THE HIGHWAY

You are reminded that the cycle section is on open roads, so please ensure that you observe the rules of the road at all times. Any reported infringements, such as crossing white centre lines, or failing to take due care will result in a DQ. It is also illegal and may result in a prosecution by the police.

Please recognise that Race Marshals are not permitted under British law to stop the traffic and will not do so under any circumstances. Marshals are there to give direction only. Competitors are responsible for making their own decisions as to whether it is safe to proceed or not. If in doubt competitors should stop!

Endurance Revolution



Swim * Cycle * Run
#EnduranceRevolution

RIGHT OF WAY

You must take the utmost care at junctions and should note in the course details that you do not have right of way at a number of sections, check that the junction is clear before continuing. You must obey the Highway Code, which is also the Law. Don't take risks to save two seconds.

NON-DRAFTING

This race is a non-drafting race for all categories meaning competitors are not allowed to take shelter behind or beside another competitor or motor vehicle during the cycling segment of the race.

The draft zone is a rectangle measuring ten metres long by three metres wide, which surrounds every cycle on the cycle course (approximately the size of an estate car). The front edge of the front wheel defines the centre and top edge of the rectangle. A competitor may enter the draft zone of another competitor, but must be seen to be progressing through that zone.

A maximum of 20 seconds is allowed to progress through the draft zone of another competitor. If an overtaking manoeuvre is not completed within 20 seconds, the overtaking cyclist must drop back. Time penalties and DQs will be issued by the referee for infringements.

CYCLE HELMETS

Approved hard shell helmets will be compulsory and must be worn throughout the cycle section. They must be fastened prior to mounting your cycle and neither undone nor removed until your bike is racked.

BIKES

It is the responsibility of all competitors to ensure that their bike is in a roadworthy condition and adheres to the rules and regulations as specified by the British Triathlon Federation.

RACE NUMBERS

On the day you will be issued with one race number which must be clearly visible on your back for the bike and your front for the run. Do not cut or fold these race numbers, as penalties will be issued for number mutilation. Please ensure your race number is visible as you exit transition for the bike, when leaving transition for the run and most importantly when you cross the finish line. For relay teams, the swimmers will not require a number, the cyclist will wear their number on their back and the runner will wear their number on their front.

You will need a race belt for your race number. These can be purchased on the day if you don't have one.

REGISTRATION PROCEDURE AND TIMINGS

Registration Open Sunday 6.15am

Please do not leave it until five minutes before registration closes to attend. Ideally you should attend registration at least 45 minutes before your wave start time. If there is a queue you may find yourself unable to complete registration in time to race.

Registration will take place within leisure centre – please enter via the main foyer door. All competitors will need to register on the morning of the race.



B-Spoke Cycles

Fully Mobile Fully flexible

About Us

If you want all the benefits of a bike shop that can cater for all your needs but just don't have the time around your busy schedule, then try the B-Spoke way of life and let us come to you at any time of day or night!

Standard service packages

Bronze Service £40
Silver Service £65
Gold Service £125

Our Products

Weekly maintenance classes
Triathlon Specific servicing
E-Bike Servicing
Event Technical Support
TT/ Tri Bike fits

Triathlon specific service packages

Sprint service package £85
Olympic service package £125
Iron service package £200

0758 1510899

b-spoke1@outlook.com

cytech
Certified Mechanic



B-Spoke Cycles



b_spoke_cycles

www.b-spokecycles.com

Registration Procedure

1. Phase one – Race Pack

Collect your race pack; this will contain your event shirt, race number, swim cap, 1 x frame sticker (Please keep these safe, as they are required to allow entry into the transition area). This will also contain your electronic timing chip and ankle strap.

2. Phase 2 – Timing Chip

Collect your electronic timing chip and ankle strap. Fasten the strap by placing it around your left ankle and secure it in place using the Velcro.

RACE INFORMATION AND TIMINGS

Transition area opens at 6.15am. Bike racking will take place on Sunday morning ONLY.

Please ensure that you affix the bike number sticker provided in your race pack to your bike for security reasons. Please rack using your seat on the support frame, in alternate directions. Only competitors will be allowed into the transition area. Please attempt to rack your bike at least 20 minutes prior to your wave start time. There is no distance advantage to be gained with any of the rack locations.

During the race, only racing competitors will be allowed through the transition area.

Removal of your bike from the transition area will not be possible without your race number, which corresponds with your stick-on bike frame number on your handlebars. If challenged, please be prepared to show race numbers at all times.

The racking will be reused throughout the day. Once you have completed your race, please remove your bike from transition asap.

RACE BRIEFING

There will be a short race briefing on poolside 15 mins before each wave start for all athletes. Please attend this race briefing as any last-minute changes, as well as any questions will be answered here. DO NOT miss this briefing.

TRANSITION

Transition is on the Pure Vent Car Park on Bridge Street. Transition will be open from 6.15am and for the remainder of the event. Entries in Wave 1 will have priority.

You will enter and exit the transition area the same way following both swim and bike legs. (Please see the transition layout diagram)

Please keep the amount of equipment left in transition to a minimum. Transition boxes etc. are not allowed to be kept in transition as per BTF rules.

ENTRY TO TRANSITION

To gain entry to transition to rack your bike you will need to:

- Register at the registration desk.
- Attach your bike sticker to the frame of your bike.
- Display your race number(s).
- Put your helmet on and ensure its fully fastened.
- Walk to the transition entrance where you will be greeted and shown where to rack your bike.
- No boxes or large bags to be left in transition.

TRANSITION LAYOUT:

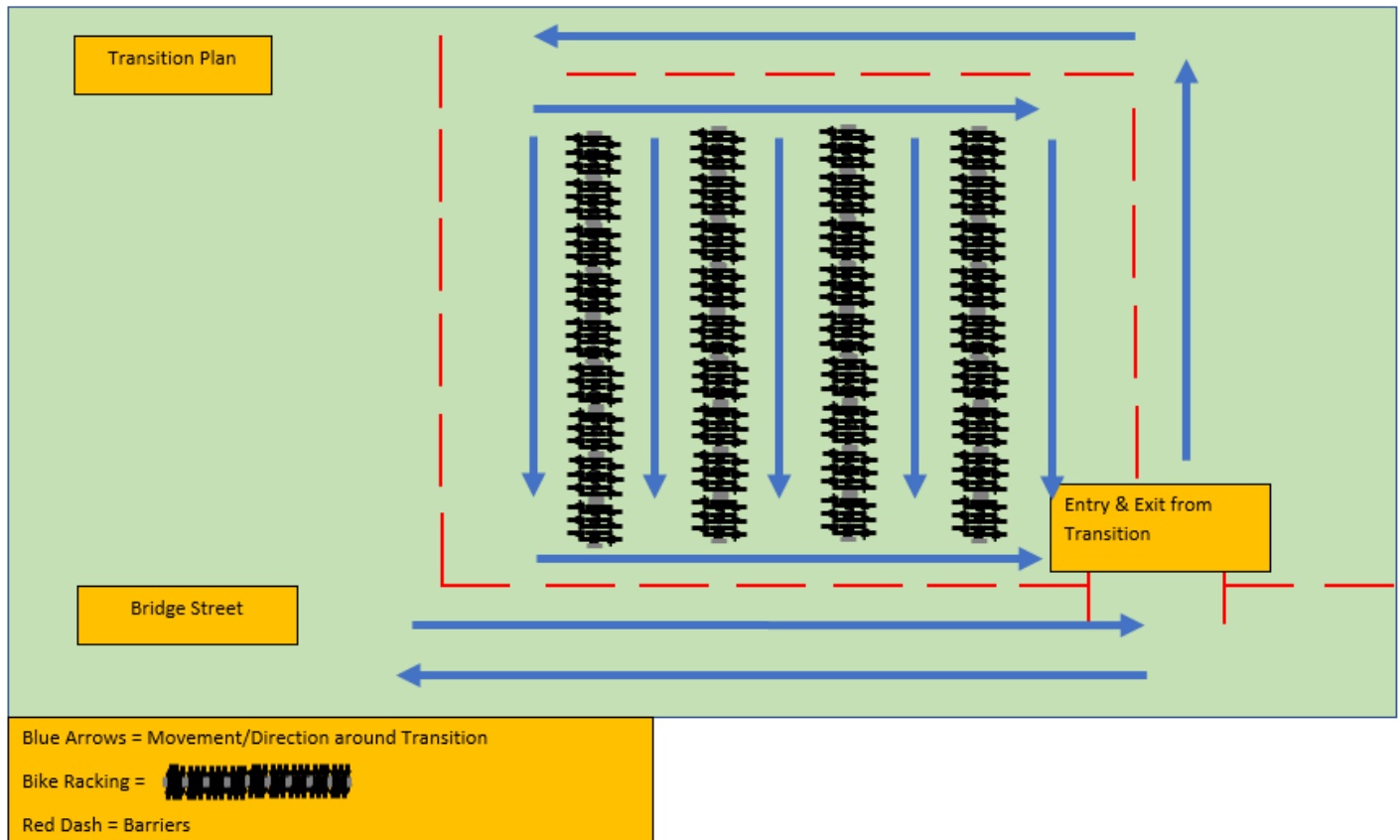

SECTION ON BIKE RACK

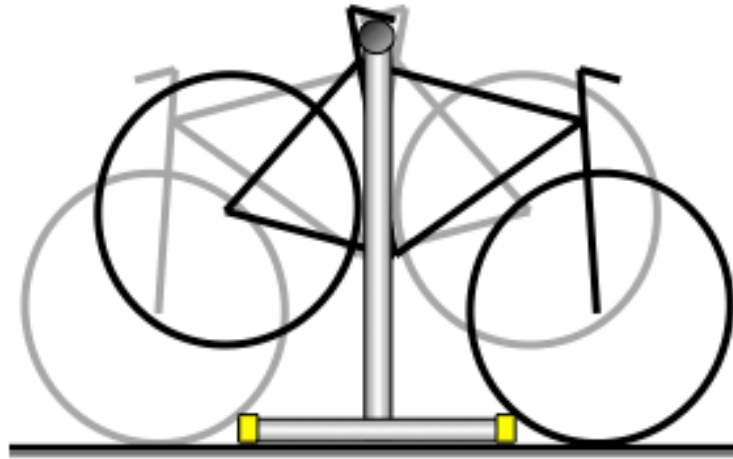

Rack your bike by the seat against your race number. Your front wheel will be the same side of the racking as the number.

HORWICH TRIATHLON

001

Racking

PLAN ON BIKE RACK

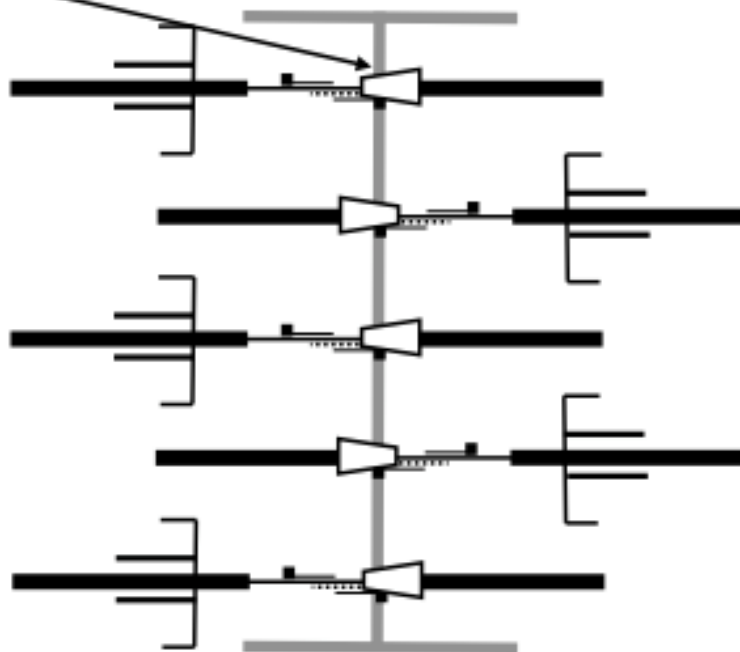

goodr **SUNGLASSES**

GOODR ARE PROUD TO SUPPORT
EPIC EVENTS TRIATHLON
SERIES 2019.



THE RUN GOODR MANIFESTO

Our mission is simple, we're all about creating *fun, fashionable,* and *functional* sunglasses that everyone can afford. We started Goodr because we think running is fun and your gear should be too.



AVAILABLE FROM THE ENDURANCE STORE

Get yours from The Endurance Store: www.theendurancestore.com

NO SLIP. NO BOUNCE. ALL POLARISED. ALL FUN.

The Endurance Store



goodr www.goodr.co.uk

THE SWIM - 500M



The 500m swim will be conducted in a series of waves. The wave times have been selected using your submitted estimated swim times (Slowest first). Each lane will contain three swimmers, set off by whistle at 10 second intervals in the order orange, green and pink.

Lane 1 will swim anti-clockwise, Lane 2 clockwise and so on. Please refer to the pool organisation diagram below.

All competitors will push start in the water, diving into the pool is not allowed at any time, tumble turns are allowed. The lane order has been selected on swim times, however, if you do catch the swimmer in front, please tap their feet a couple of times, it is then the responsibility of the swimmer in front to let you pass at the end of the current length. Please be patient and do not attempt to overtake during the length. A 30sec penalty may be awarded if the front swimmer does not obey this rule and a 30sec penalty may be awarded for un-sportsmen like conduct in the pool.

On completion of 18 of the required 20 lengths a "2 laps to go" board will be placed into the water in front of you.

There is a short run to the transition area and it is recommended that you leave a pair of trainers on poolside for this. **The route will be checked for sharp objects, but it cannot be guaranteed to be clear, therefore a barefoot run is completed at your own risk.** Exit to the rear of the pool by the fire exit and follow the route out, across the road turning on right onto Bridge Street and then into transition. Be aware of runners/cyclists from earlier waves exiting transition.

PLEASE NOTE THAT ALL CLOTHING AND HELMETS MUST BE IN TRANSITION, YOU ARE NOT ALLOWED TO LEAVE CLOTHING AND HELMETS AT THE SIDE OF THE POOL.

Due to the large number of competitors and the limited pool time, we have had to introduce an 18-minute cut off for completing the swim. If you are still in the pool at 18 minutes you will be asked to stop swimming and continue to the bike section. You will NOT be disqualified, and you CAN continue the race however you will not be able to complete all 20 lengths.

You will need to arrive on poolside 15 minutes before your start time to be present for the compulsory briefing.

As per the BTF rules competitors are not allowed to wear neoprene shorts or swim suits in the pool.

POOL ORGANISATION

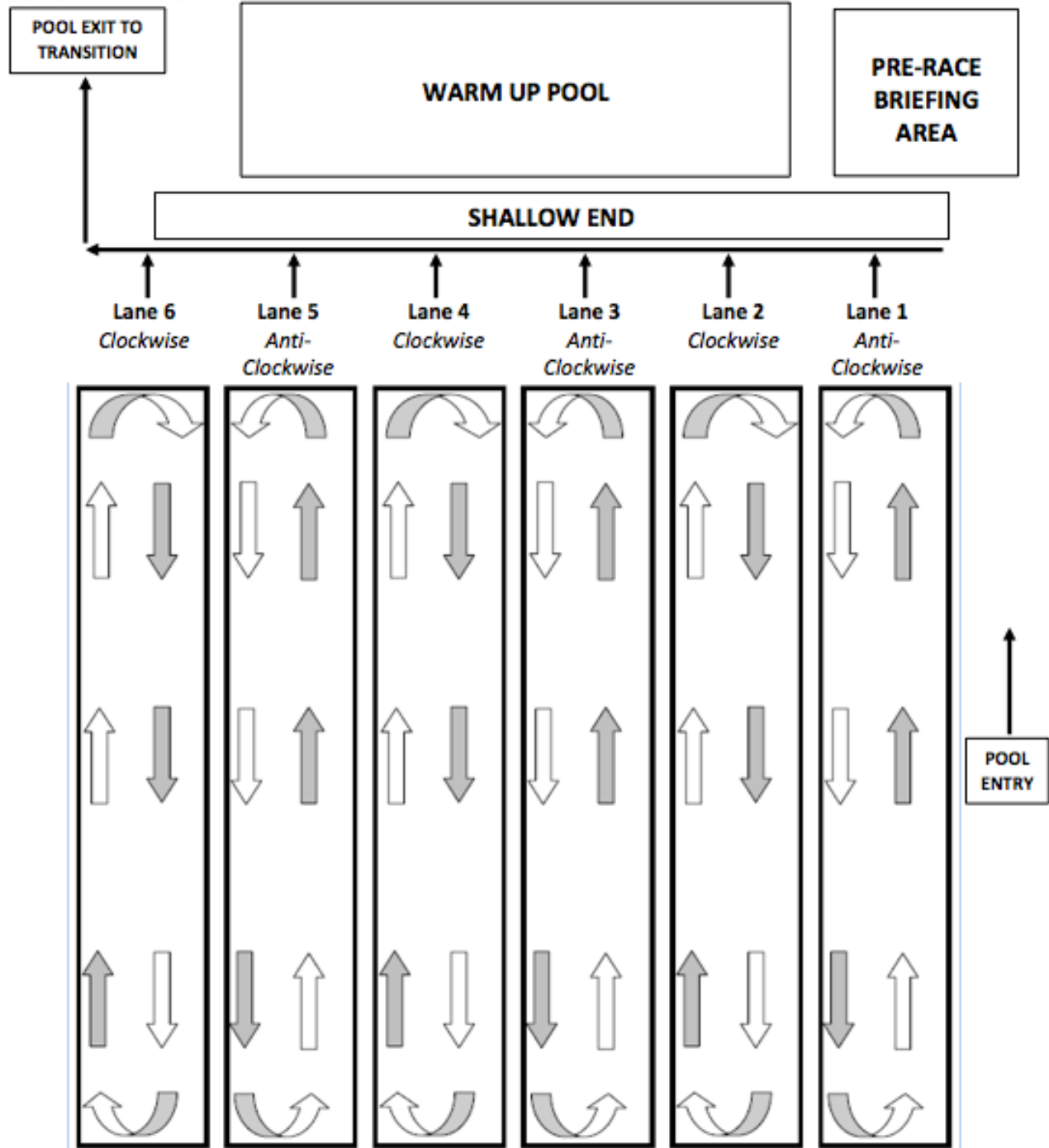

THE BIKE - 24.6 miles (39.6km)

<https://www.strava.com/routes/3417898>



For the bike section signs will be in place like those pictured below, these may point left, right or straight on and will only be in place before a junction or at a run turn. At specific points on the course marshals may be in place, this will generally occur where you join a busy road. If a marshal tells you to slow or stop you must do so or you will be disqualified, marshals cannot legally stop or direct traffic in any way. After leaving transition, you will mount before the line on Bridge Street.



After approximately 2 miles there is a left turn on to Walkers Fold Road, which is sign posted Belmont at the Bob Smithy Pub. There are also some steep descents with hairpin bends at the bottom, so again plan your course and speed accordingly do not be tempted to cross the centerline.

At the end of this section (5 miles) there is a left-hand hairpin and a fast decent. The bottom of this decent is

the junction with the A675. **SLOW DOWN! AND GIVE WAY IF NECESSARY.** Traffic will be coming from your right, although there is now a cycle lane on this road and trees have been cut back improving your view of traffic. Continue along the A675 through Belmont and Abbey Village until 13miles where you will arrive at the junction with the M65 motorway. Take the first left off the roundabout onto the A674, Chorley Road, following signs for Wheelton up the hill.

At approx. 16.5 miles, just at the start of the dual carriageway, you need to take a sweeping left turn onto Blackburn Road (B6228) heading towards Eaves Lane. Having crossed over the M61 and canal bridge (straight on at mini roundabout) at approximately 18 miles keep left along Eaves Lane and at 18.5 miles turn left (straight on as the crow flies) continuing along Eaves Lane. Travel a further 300m to a mini-roundabout keeping left as the road turns into Cowling Brow (sign posted for Cowling Industrial Estate).

As you cycle on through Limbrick at approximately 19.5 miles there is a narrow bridge, please be aware of oncoming traffic. After Limbrick the route runs parallel with the Motorway and at approximately 21 miles the road bears left onto Babylon Lane and over the motorway bridge.

You should continue past the left turn into Horrobin Lane, past the Anderton centre to reach the end of the lane at 22.2 miles. Here you will turn left onto Bolton Rd (A673) and then continue into Horwich town centre.

At 24.5 miles, there are a set of traffic lights. Every competitor must dismount just prior to the lights, cross safely and then mount where instructed. Continue around the bend until you arrive at the dismount line where you will dismount your bike and run into transition in the same place as bike out.

THE RUN - 5.4 miles (8.6km)

<https://www.strava.com/routes/3417836>



For the run section signs will be in place similar to those pictured below, these may point left, right or straight on and will only be in place before a run turn. There are no drink stations on the run course, so please ensure you carry sufficient provision or you are suitably hydrated before you commence the run.



On completion of the bike section, having correctly racked your bike, you will then exit transition. Again, turning left up the hill out of Horwich. Run up the hill for 0.5 miles to the marshal, turning left into Gingham Brow. Stay on this track, which becomes footpath and eventually reaches Foxholes Road. Turn right up Marklands Road.

After 1 mile, you reach the top of the tarmac road at a T Junction. Here turn left on to Georges Lane. Keeping to the right, run past Old Rake Car Park, where the surface begins to change from tarmac to

loose gravel and then on to cobble path. At approx. 2 miles you will turn right, through a gate and then begin the direct ascent up to the Pike Monument itself. This is the highest point of the course. Go to the LEFT of the tower and then follow the steps off the top of the Pike

Begin your decent down off the Pike, down the steps and at the gate with George's Lane turn left and retrace your steps all the way back to the finish.

Rivington Pike is very exposed to the elements and you should be prepared - bring a windproof/waterproof jacket just in case the forecast is poor! The descent from Rivington Pike is rocky and slippery underfoot, off-road shoes are recommended and you should take your time when descending.

TIMING AND RESULTS

Please ensure your timing chip is in place on your left ankle for the duration of the race using the strap provided. There will be a timing mat on the entry of transition and at the finish line. When you have crossed the timing mat at the finish, please remove your chip & strap and place in the bucket provided.

Any lost or missing chips will be charged at £10 each and this will be taken automatically from your debit/credit card.

RESULTS

A set of provisional results will be available to download later the same day from www.epicevents.co.uk any queries relating to provisional results posted on the web must be e-mailed to events@epicevents.co.uk by Monday following the event, after which time all results will be deemed as final and complete.

PRIZE GIVING AND PRESENTATION

Presentation will take place at 16:00 approx. It will take place at the Registration area. You must attend presentation to collect your prize. Prizes will not be posted out following the event.

Prizes will be awarded for the following categories (subject to minimum entry of 3 per age group as per the finalised entry list):

- ❑ Open Male 1st 2nd 3rd (All Age Groups)
- ❑ Open Female 1st 2nd 3rd (All Age Groups)
- ❑ Male V40; V50; V60+ = 1st place
- ❑ Female V40; V50; V60+ = 1st place

If you win an Open Prize, you will not be eligible for either the V40, V50 or V60 individual Prizes.

MEDICAL ADVICE

If you have any known medical condition (such as diabetes, asthma, allergy to penicillin, etc.) please ensure you have informed us prior to the race on your application. Following registration, where you will be issued with your race numbers, please write all medical details including any medication taken on the back of your race number as well as next of kin & emergency contact details and put a small indelible red cross on the front of your number. This is not just an administrative request, it could be a matter of life and death in an emergency. This will only be used in the event of you being involved in an accident. Whether you have a medical condition or not, if you feel unwell on race day -don't race!

HORWICH LEISURE CENTRE

Horwich Leisure Centre provides an excellent venue for Horwich Triathlon again this year. Please ensure you treat the facilities with respect, especially the WCs and changing facilities. The leisure centre café will be open for business during and after the event.

OTHER RELEVANT INFORMATION

STRAVA

We have two Strava challenge segments for you on the course. The segments are:

Côte de Horwich with Mountain Fuel:

<https://www.strava.com/segments/9410631>

Limbrick Leg Killer:

<https://www.strava.com/segments/11484336>

On the Tuesday following the event, we will collate the results from all the club members who raced and announce the winners via Strava, the Epic Events Facebook page and Twitter. Winning is a lucky dip draw so everyone is in with a chance and

we have some fabulous prizes donated to us from our amazing sponsors.

NOTE – You must be a member of the Epic Events Strava Club and you must ensure your race stats are uploaded no later than Tuesday 12:00 following the event.

You can join the club here:

<https://www.strava.com/clubs/epic-events-115948>

EPIC CLUB CHAMPIONSHIPS

This year at Horwich Triathlon we are launching the Epic Club Championships! The rules are simple, all finishers will receive points based on their finish position and the club with the most points will win. The more club members, the more points and the higher your finish position, the more points!

You need a minimum of 3 ladies and 4 men to take part from your club. The winning club will win a £1000 donation made to a children's charity/sports group/club of their choice as well as bragging rights for the rest of the year!

Finally

On behalf of Epic Events, all the team would like to wish you well with your race and hope you have a safe and enjoyable event.

Yours in sport

EPIC EVENTS

e-mail: events@epicevents.co.uk

website: www.epicevents.co.uk